

REVISIONS			
REV	REVISED PER	Date	Approved
A	first release	2006/June/6	JHH

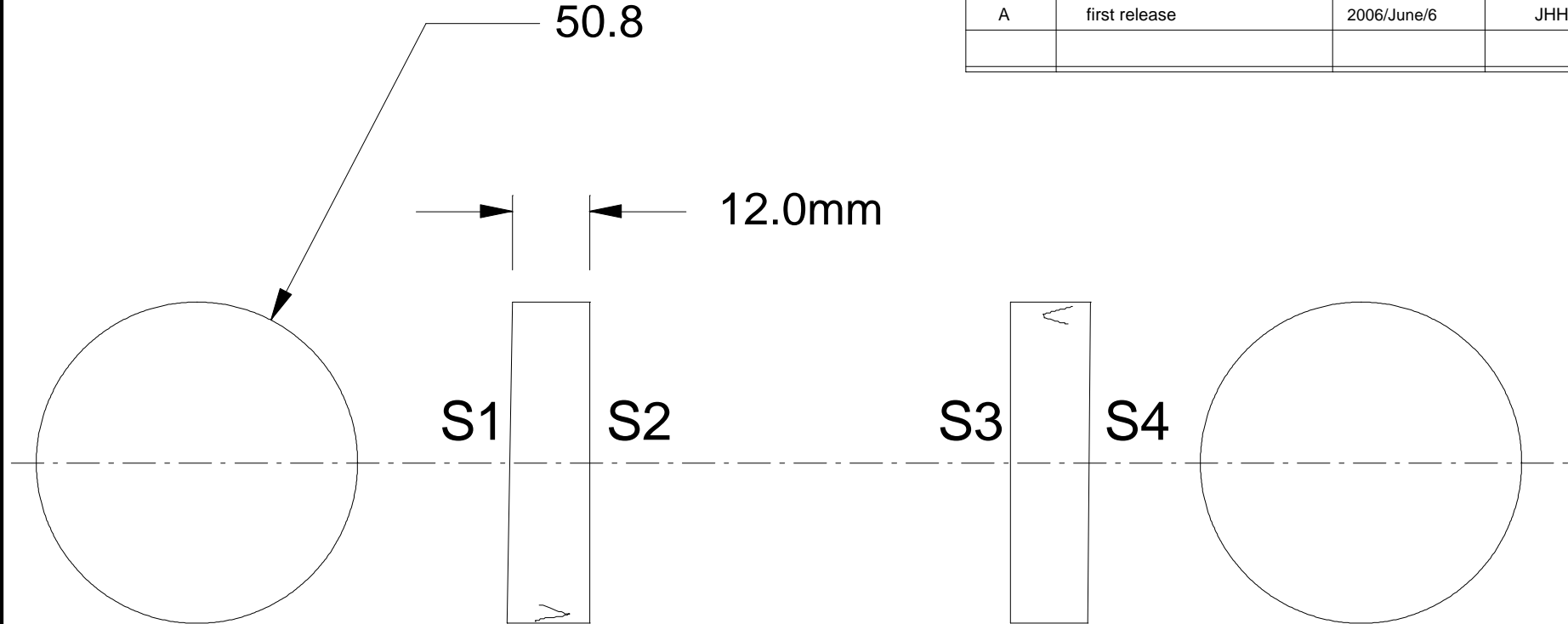

1. Clear aperture: 85%
2. S2, S3 Inside Surfaces Matched to: $\lambda/100$ or better
3. S1, S4 Outside Surfaces; $\lambda/20$ or better
4. Uncoated
5. Surface quality: 10/5 or better
6. Wedge: 30 minutes of wedge
7. Indicate max thickness with arrow on side pointing towards matched side
8. Surfaces to be matched with opposing wedges as shown
9. Serialize matched pairs with work order number and -001, 002, 003...

2" Fabry Perot Etalon Plates

LightMachinery OP-2811

dimensions mm	material: Fused Silica Corning 79800A
Tolerances (unless otherwise noted)	Scale 1:1
X ± 0.5 A $\pm 1^\circ$	Third angle projection
X.X ± 0.1 A.A $\pm 0.1^\circ$	
X.XX ± 0.025	Drawing Template QT-730-002-E

This design and print is the property of LightMachinery, Inc., and shall not be used as the basis for the manufacture or sale of apparatus without the written permission of LightMachinery, Inc.